

KOHLER®

UNINTERRUPTIBLE
POWER



KOHLER EL300DSP

10-120kVA

Technical Specification

Document Control

ISSUE	DATE	REVISION SUMMARY
TS_781_01	05/08/2024	Rebranding to KUP
TS_781_02	19/8/2024	Correction to Input Current and heat dissipation

Useful Contacts

UK

www.kohler-ups.co.uk	Kohler Uninterruptible Power web site
ukservice.ups@kohler.com	Service department – booking service, fault reporting etc.
uktechnicalsupport.ups@kohler.com	Technical queries
uksales.ups@kohler.com	Hardware sales
ukservicesales.ups@kohler.com	Extended warranty agreements etc

Contents

CHAPTER 1 – GENERAL DESCRIPTION	3
1.1 INTRODUCTION	3
1.2 FUNCTIONAL DESCRIPTION	5
1.3 MODES OF OPERATION	7
1.3 COMPONENT DESCRIPTION	9
1.3.1 CABINET	9
1.3.2 CONTROL DISPLAY	9
CHAPTER 2 – COMMUNICATION	11
2.1 INTRODUCTION	11
2.2 SERIAL PORT CONNECTION	11
2.2 DRY CONTACT CONNECTIONS	12
2.3 CONTROLS	12
2.3.2 DRY PORT CONTACTS	13
2.3.4 SNMP CARD SLOT	14
CHAPTER 3 – TECHNICAL SPECIFICATION	15
3.1 GENERAL SPECIFICATIONS	15
3.2 RECTIFIER SPECIFICATIONS	15
3.3 BATTERY SPECIFICATIONS	16
3.4 INVERTER SPECIFICATIONS	16
3.5 BYPASS SPECIFICATIONS	16
3.6 OPTIONAL EXTRAS	17
3.7 MECHANICAL SPECIFICATIONS	17
3.8 MAXIMUM OUTPUT MCB	17
3.8 MAXIMUM INRUSH CURRENT	17
3.9 HEAT DISSIPATION	18
At 100% Load, Battery fully charged, running inverter mode	18
At 100% Load, Battery fully discharged, running inverter mode	18
At 100% Load, Battery fully charged, running changeover mode	18
At 100% Load, Battery fully discharged, running changeover mode	18
At 120% Load, Battery fully discharged, running changeover mode	18

CHAPTER 1 – GENERAL DESCRIPTION

1.1 INTRODUCTION

KOHLER EL300DSP Series Emergency Lighting (EL) Inverters are double-conversion; Changeover / Inverter EL INVERTER's manufactured with the latest IGBT and PWM technology, to produce pure sine wave output to the lighting loads.

KOHLER EL300DSP Series units are 3-phase in/3-phase out devices, and they are installed between a three phase lighting load, and a 3-phase+N mains supply

The advantages of using EL300DSP EL INVERTER:

Power blackout protection:

If the mains power fails, the EL INVERTER continues to supply the critical load using the energy stored in its batteries, keeping the load immune from power disturbances.

Increased power quality:

The EL INVERTER has its own internal voltage and frequency regulating software, which ensures that, its output to the critical load is maintained within close tolerances, independent of voltage and frequency variations on the mains power lines.

Fully digital control by three DSP controller for each EL INVERTER:

The EL INVERTER is controlled by 3 independent DSP chips which are communicating each other continuously. Rectifier, Inverter and User Interface modules have separate DSP's to achieve the highest performance. Each DSP module has many parameters to control and monitor the system to have the best electrical power output and to help diagnostic.

Increased noise rejection:

By rectifying the input AC power to DC power and then converting it back to AC (Double-Conversion) any electrical noise present on the input mains supply line is effectively isolated from the EL INVERTER output. Therefore the critical load is supplied with only clean and uninterrupted AC power.

Key features

- PWM and IGBT technology
- Pure sinusoidal output wave form and true on-line topology
- High input power factor (IGBT rectifier), Input current limiting
- Low input current THD (IGBT rectifier)
- Low output voltage THD
- High AC/AC and DC/AC efficiency (up to 94%)
- High charger capacity
- 3 separate DSP (Digital Signal Processor) control
- Cold-start feature
- Static By-Pass
- Bypass leakage current sense system
- Maintenance bypass switch and warning system, by-pass short circuit protection
- LCD alphanumeric display panel providing battery, load, voltage, power and status information in detail to user
- Improved diagnostics and correct fault information
- Up to 192 event memory record system (7000 alarms or warnings total)
- Real time clock and calendar system
- Overload operation continuous at 100%-120% load, 10 minutes at 120%-150% load, 1 minute at 150%-180% load
- Output overload, over-current and short circuit protection, output current limiting
- Reliable operation at even 100% unbalanced load condition
- Non-linear load supply feature (CF 3:1)
- Double polarity battery (with common terminal)
- Automatic and manual battery test and battery temperature compensation features
- 3 separate maintenance clock counters
- Battery charge with current limiting
- Automatic and manual boost charge feature
- Battery deep discharge protection
- Temperature protection with 3 separate sensors
- Charger output short circuit protection
- Interactive communication
- Diagnostic and settings with PC ability
- 10 dry contact alarm relay outputs as standard (Digital/Contact inputs of EL control)
- AT command set definitions for dump modems
- Emergency power-off support
- Conformity to international and local standards
- AC input and output filters
- CE compliance
- Input, bypass and load phase order protection
- 2 separate RS232 communication ports (standard)

Optional features

- Multi EL INVERTER monitoring on same communication line by RS485 (optional)
- Improved remote monitoring panel system
- RS232 port multiplexer
- Direct network connection with optional SNMP support
- MODBUS Adapter
- Input and output isolation transformers
- Optional leakage current alarm system
- DC Earth leakage protection
- High IP rating
- Other voltage options

1.2 FUNCTIONAL DESCRIPTION

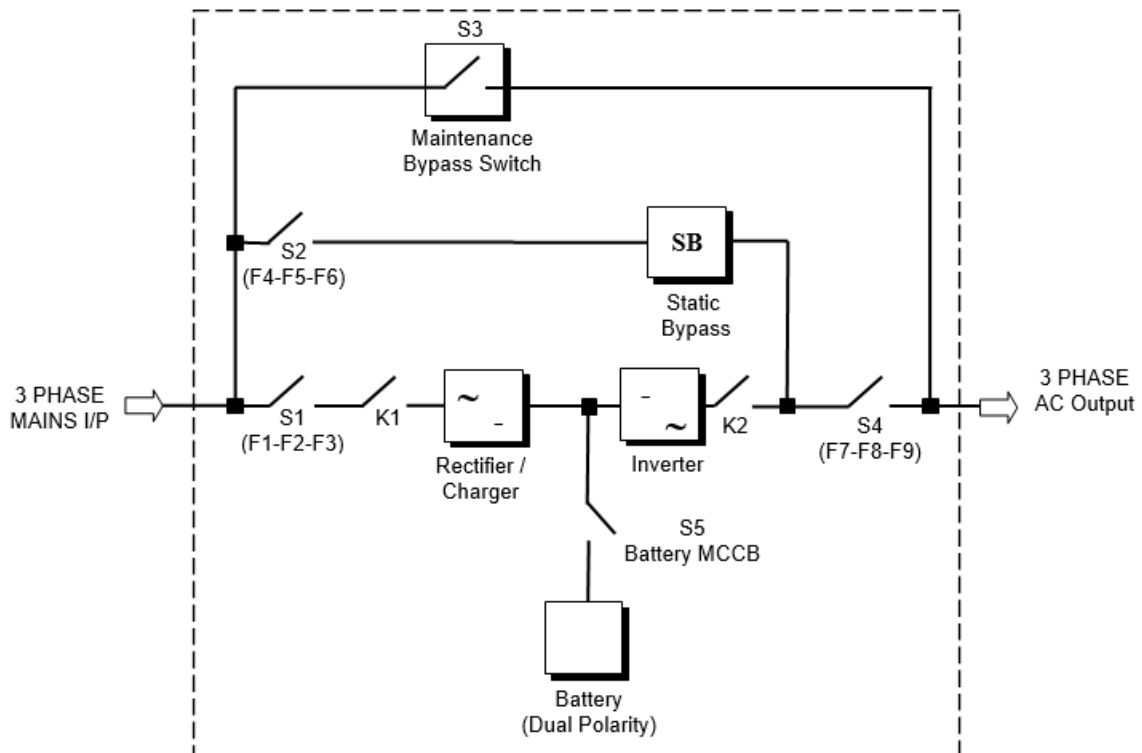

- S1 (F1-F2-F3)** : Rectifier Input Switch / Fuse
- S2 (F4-F5-F6)** : Bypass Input Switch / Fuse
- S3** : Maintenance Bypass Switch
- S4 (F7-F8-F9)** : Output Switch / Fuse
- S5** : Battery MCCB
- K1** : Rectifier Input Contactor
- K2** : Inverter Output Contactor

RECTIFIER: In EL300DSP Series EL INVERTERS, a controlled IGBT rectifier with PWM technique is used to increase input power factor (PFC) and to decrease input current harmonics (THDI). The IGBT rectifier accepts AC input and produces a dual polarity DC voltage for both supplying the inverter and charging the batteries.

BATTERIES: Batteries are used as reserve DC power supply for the Inverter in case of mains failure. Batteries are connected in series with a centre-tap output to obtain a dual polarity DC supply. Batteries are discharged by the inverter during mains failure. The discharged batteries are re-charged by the IGBT Rectifier on a constant voltage / current limiting basis, if AC mains power is available.

INVERTER: It is manufactured by using the latest IGBT and DSP (Digital Signal Processing) technologies, and Pulse Width Modulation (PWM) technique. The Inverter converts the DC BUS voltage supplied by the IGBT Rectifier and / or the batteries into a well-regulated, fully digital controlled AC voltage with fixed voltage and frequency.

The output of the inverter is used to supply the critical loads connected to the EL INVERTER output.

STATIC TRANSFER SWITCH (STS): This is an electronically controlled transfer switch, which enables the critical load to be connected either to inverter output or to by-pass power source. During normal operation, the load is supplied by the inverter output, but in case of an overload or a EL INVERTER failure it is automatically transferred to the bypass source without any interruption.

1.3 MODES OF OPERATION

The EL300DSP can be configured to operate in one of three modes to suit the degree of supply integrity required for a particular lighting application

Changeover mode

When operating in the 'changeover' mode the rectifier is turned on to provide battery charging. The inverter is turned on and operating on standby (off load) the bypass-side of the static switch is turned on to connect the SI OUPUT to the AC INPUT via the internal bypass line.

If the utility supply fails, the static switch will transfer the SI OUPUT to the inverter within 10ms. However, as the utility supply is in a failed state the rectifier is inoperative and the inverter will be powered solely from the batteries (see Figure 2.4).

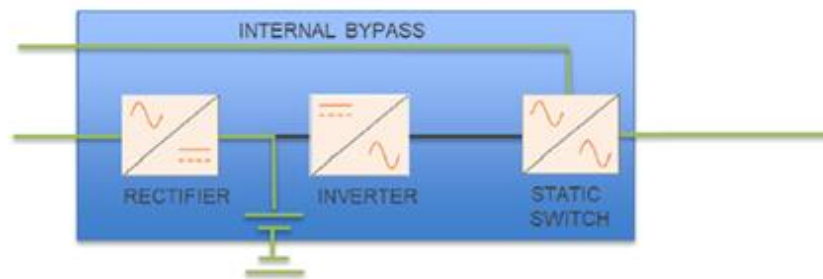

Figure 1.1

Inverter mode

When operating in the 'inverter' mode the rectifier is turned on to power the inverter and provide battery charging.

The inverter is turned on and the inverter-side of the static switch is turned on to connect inverter to the SI OUPUT.

The emergency luminaires are powered from the regulated inverter output.

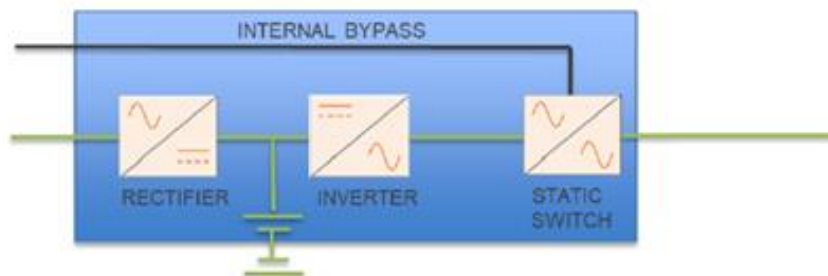

Figure 1.2

On battery operation

If the mains supply fails, the rectifier will turn off, but the inverter will continue to operate from battery power until the batteries reach their end-of-discharge voltage; at which point the inverter will shut down and disconnect the SI OUTPUT supply.

If the AC INPUT supply is restored before the batteries are fully discharged, the rectifier will turn on automatically to once again power the inverter and recharge the batteries.

The whole process of switching between rectifier and battery power is totally transparent to the emergency luminaires.

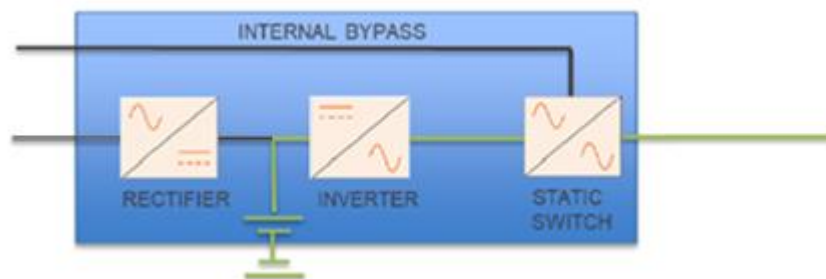

Figure 1.3

1.3 COMPONENT DESCRIPTION

1.3.1 CABINET

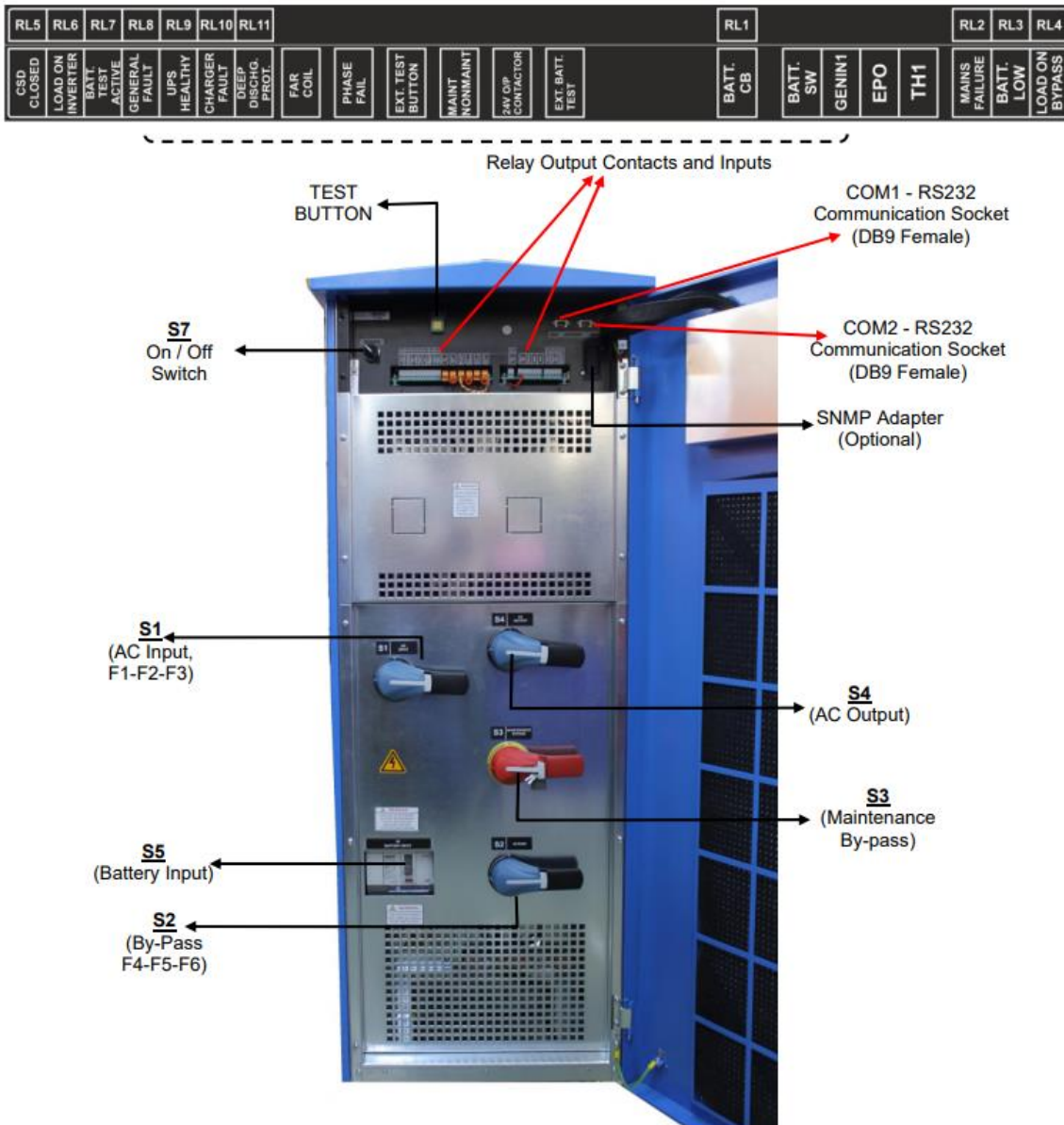
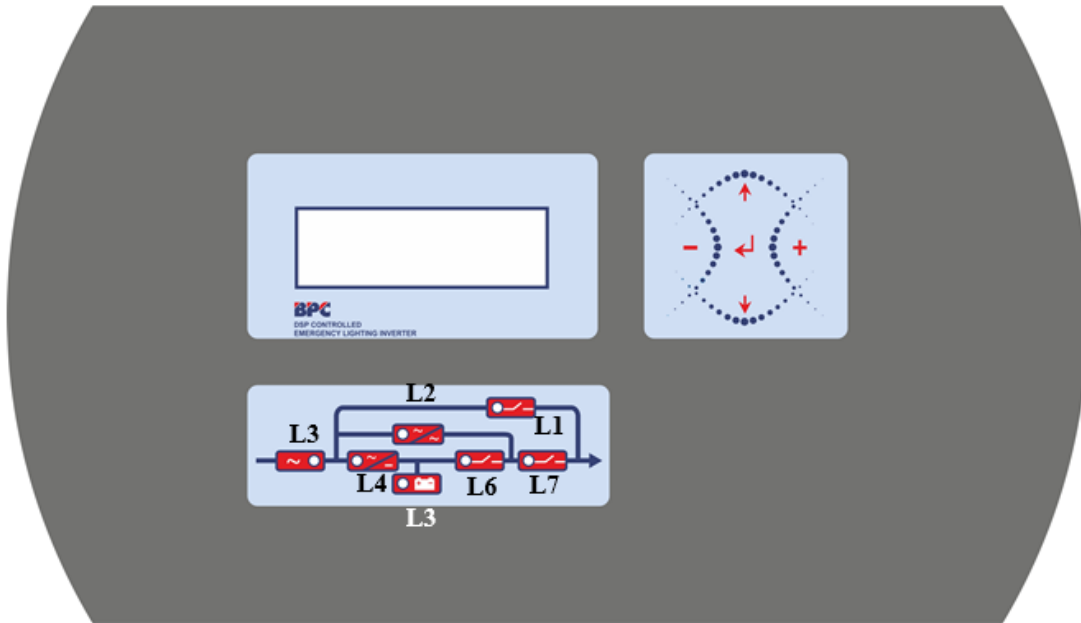

Figure 1.4 - 80-120 kVA Fuses and Switches Panel

1.3.2 CONTROL DISPLAY

The front panel of EL INVERTER, consisting of a 4 lines alphanumeric display, 7 status lamps, plus 5 function keys, allows the complete monitoring of the EL INVERTER status. The mimic flow diagram helps to comprehend the operating status of the EL INVERTER. By using the function keys operator can move between menus and change some parameters.



- L1 : Maintenance bypass switch on indicator lamp**
- L2 : Load on bypass indicator lamp**
- L3 : Input voltage indicator lamp**
- L4 : Rectifier run pilot lamp**
- L5 : Battery operation indicator lamp**
- L6 : Load on EL INVERTER indicator lamp**
- L7 : Output switch on indicator lamp**

There are 5 control buttons on the EL INVERTER Front panel, ENTER button provides selection, up and down buttons provides to surf on menus, (+) and (-) buttons are used for adjustments or option selection.

CHAPTER 2 – COMMUNICATION

2.1 INTRODUCTION

Following external connections are available for EL300DSP Series EL INVERTERS.

- Communication by serial port connection.
- Dry contact (interface board) connections.
- Remote monitoring panel.

Using one of above communication options is satisfactory for remote monitoring and control in most of the systems, some systems may use 2 or 3 of above options at the same time. In this case accessories group produced by KOHLER may help to make appropriate solutions.

2.2 SERIAL PORT CONNECTION

Two serial communication ports are included on EL300DSP Series EL INVERTER cabinet (com1 and com2). Both may be used for user communication. But in service status duty of com2 port is changed and set as service port in Options Menu.

All data of EL INVERTER can be accessed by this communication way. All the voltage and current values measured by EL INVERTER, alarms, warning and status messages can be monitored.

The maximum length for RS232 communication cable should be 25 meters. For remote panel and EL INVERTER connection the same pin configuration is valid. Connection terminals of RS232 cable is shown below for com1 and com2 ports:

EL INVERTER Side	Panel Side
9 Tx	2 Rx
7 Gnd	5 Gnd
6 Rx	3 Tx

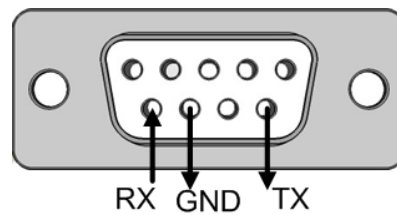

2.2 DRY CONTACT CONNECTIONS

Some important events of the EL INVERTER can be monitored or controlled by these connections. These functions are listed below:

RL5	RL6	RL7	RL8	RL9	RL10	RL11		RL1		RL2	RL3	RL4								
CSD CLOSED	LOAD ON INVERTER	BATT. TEST ACTIVE	GENERAL FAULT	INVERTER HEALTHY	CHARGER FAULT	DEEP DISCHG. PROT.	FAR COIL	PHASE FAIL	EXT. TEST BUTTON	MAINT. NONMAINT	24V O/P CONTACTOR	EXT. BATT. TEST	BATT. CB	BATT. SW	GENIN1	EPO	TH1	MAINS FAILURE	BATT. LOW	LOAD ON BYPASS

Figure 2.1

2.3 CONTROLS

BATT SW

Provides an output to external battery breaker. Enables the tripping of external battery breaker during specific set conditions.

GENIN1

Allows the Inverter to know when Generator is in operation.

The inverter can be set to open its synchronisation window during generator operation

The Inverter can be set to reduce charging current during generator operation

EPO

An external EPO circuit can be connected to the EPO terminals.

The external circuit must be 'normally open' to the EPO terminals.

If the EPO circuit is operated (short-circuit) the EL300DSP will shut-down and disconnect the load power.

The EPO terminals are volt-free and should be connected using a screened cable with 1 pair (0.5 mm²) and maximum length of 100m.

Note: If an external EPO circuit is not connected, a shorting link must be connected to the EPO terminals (as shown).

The terminals can be changed to NC in the display firmware.

TH1

The battery temperature can be measured by a thermocouple sensor that is attached to the TH1 connection, supplied as an option from KOHLER.

TH1 will enable the ability to provide temperature compensation charging

FAR COIL

A fire Alarm Relay (FAR COIL), with a 24V DC coil input is mounted on the ELOPT01 board and its coil is connected via terminals 1 and 2 of CN13, to the 24V DC control output of the remote Fire Alarm Panel. Under normal operating conditions this relay is energized and if the external 24V DC supply to terminals 1 and 2 is lost (in case of a fire alarm) the FAR will be de-energized by forcing the load on to the inverter and de-energizing the none-maintained contactor, regardless of the position of the switch connected across CN16 terminals of MAINT. / NON-MAINT. That means under fire alarm conditions the load is turned on, anyway.

PHASE FAIL

An external phase failure device, via external phase fail terminals (two terminals of CN14 on the ELOPT01 board, labelled as PHASE FAIL) can also be used to externally monitor a phase which is not supplying the machine. Two terminals of CN14 should normally be kept shorted under normal operating conditions. When the external phase failure device opens these terminals, the output is switched to inverter.

EXT. TEST BUTTON

A N/C momentary TEST BUTTON is connected across the two terminals of CN15 on the ELOPT01 board (labelled as EXT. TEST BUTTON), providing an immediate test that the system is working OK by forcing the

load on to the inverter and de-energizing the none-maintained contactor if fitted. (The NC contacts of the contactor should be used for connecting the load to the Inverter outputs.)

MAINT / NON MAINT

Two terminals of CN16, MAINT. / NON-MAINT on the ELOPT01 board are for connection to an external switch so the end user can control the output of the system (i.e. the lights are on or off) if a NC none-maintained contactor is used in series with the Inverter output. For maintained operation this switch (connected between two terminals of CN16) should be “open” and for non-maintained operation it should be “closed”. The none-maintained contactor mentioned above should have a coil voltage of 24V DC, and this voltage is available across the two terminals of CN17 on the ELOPT01 board (max 3 Amps). Even if this switch is closed for non-maintained operation, the non-maintained contactor is de-energized and the lights are turned on in case of power failure.

24V O/P CONTACTOR

24VDC output for external output contactor.

Contactor should be Normally closed and directly fed from this supply.

In the event of a mains failure the contactor will close.

In the event of FAR COIL / PHASE FAIL /EXT TEST / (MAINT/NON MAINT) being activated the contactor will close

EXT. BATT TEST

NC connection, opening this connection provides an immediate test that the system is working OK by forcing the load on to the inverter and de-energizing the none-maintained contactor if fitted. (The NC contacts of the contactor should be used for connecting the load to the Inverter outputs.)

Suitable for connecting to DALI / KNX and external lighting controls to perform regular test.

2.3.2 DRY PORT CONTACTS

The EL300DSP provides eleven hard-wired ‘system status’ outputs that can be used to drive remote signalling and/or monitoring facilities. These output are switched by volt-free relay contacts and are normally closed/open (selected in display). The contacts are rated for 42VDC @ 0.5A.

As shown in Figure 2.1, the eight switched alarm outputs are:

- **RL1 – BATT CB**
Battery Circuit Breaker is Open or Closed
- **RL2 – MAINS FAILURE**
Changes state if the input voltage or frequency is out of tolerance
- **RL3 – BATTERY LOW**
Changes state if the battery voltage goes below its set value during a mains failure
- **RL4 – ON BYPASS**
Changes state if Output is being fed from Bypass Line or in Changeover Mode.
- **RL5 – CSD CLOSED**
Changes state if the external contactor on output is closed
- **RL6 – ON INVERTER**
Changes state if Output is being fed from Inverter.
- **RL7 – BATTERY TEST ACIVE**
Changes state if a battery test alarm has been received

- **RL8 – GENERAL FAULT**
Changes state if the any fault alarm is activated from the EL300DSP
- **RL9 – INVERTER HEALTHY**
Changes state if the EL300DSP is healthy with no alarms
- **RL10 – CHARGER FAULT**
Changes state if the Charger goes out of tolerance
- **RL11 – DEEP DISCHARGE PROTECTION**
Changes state if the deep discharge protection is activated.

Connections to these terminals should be made using a screened cable with 1 pair (0.5 mm²) and maximum length of 100m.

2.3.4 SNMP CARD SLOT

Simple Network Management Protocol (SNMP) is a world-wide, standardised communication protocol that can be used to monitor any network-connected device via a simple control language and display the results in an application running within a standard web browser.

An SNMP card slot, designed to house a Modem/Ethernet SNMP adapter card, is located behind a cover plate on the right-hand side of the control panel. To fit the card, you must remove the cover plate, insert the card into its connector then secure it in place using the screws that you removed when taking off the cover plate.

The SNMP adapter card contains an RJ-45 Ethernet connector which allows the EL300DSP to be connected to a network using a standard CAT-5 network cable. Once connected, the system management software agent that is preinstalled in the SNMP adapter monitors the EL300DSP operation and outputs its data in SNMP format to the connected network.

The communication exchanged between the EL300DSP and network enables event/alarm emails, server shut down (with optional licenses) and other tasks to be performed. It can also be integrated with BMS software over a local area network (LAN) for SNMP.

The SNMP adaptor requires a PC with terminal connections, and for normal operation at least one Ethernet connection.

Note: SNMP connectivity can also be implemented using an external SNMP adapter connected to the RS232 output.

CHAPTER 3 – TECHNICAL SPECIFICATION

3.1 GENERAL SPECIFICATIONS

Model	EL 310	EL 320	EL 330	EL 340	EL 360	EL 380	EL 3100	EL 3120
Nominal Output Rating (CosØ : 0,8) kVA	10	20	30	40	60	80	100	120
Nominal Output Rating (CosØ : 1) kW	9	18	27	36	54	72	90	108
Audible Noise	<57 dB	<62dB		<64dB		<68dB		
Efficiency (Load Dependant)	Upto 94% Inverter Mode / Upto 98% Changeover Mode							
Operating Temperature (Ambient)	0-40 °C							
Altitude	<1000 meters (Above See level)							
Ventilation	Forced							
Relative Humidity	< 90%							
Protection Degree	IP 20							
Standards	EN 62040-1, EN 62040-2, EN 62040-3, EN 60950-1, EN 61000-4-2, EN 61000-4-3, EN 61000-4-4, EN 61000-4-5, EN 61000-4-6, EN 61000-4-8, EN 60529, EN 50171, IEC 1009							
Transport	Packaged and On Pallet							

3.2 RECTIFIER SPECIFICATIONS

Model	EL 310	EL 320	EL 330	EL 340	EL 360	EL 380	EL 3100	EL 3120
Nominal Input Voltage	380 / 400 VAC 3 phase + N, +20 - 25%							
Max Input current (A) per phase @100% resistive load, No charge current.	14	28	43	57	85	113	142	170
Max Input current (A) per phase @100% resistive load, Full charge current.	19	41	56	76	111	152	193	239
Max Input current (A) per phase @120% resistive load, Full charge current.	22	47	66	89	131	179	227	279
Input Frequency Range	50 Hz, +/- 5%							
Input Power Factor	>0.99							
Input Voltage distortion	<10 %							
Input THDi	<5%							
Input Protection	Fuses, Voltage & Frequency tolerance, Input power limit, Input PFC							

3.3 BATTERY SPECIFICATIONS

Model	EL 310	EL 320	EL 330	EL 340	EL 360	EL 380	EL 3100	EL 3120
Battery Type	Sealed Lead Acid - maintenance Free							
Number of Blocks	60 Batteries (+/-30)							
Number of Cells	360							
Float voltage	810Vdc (+/-405 Vdc)							
Battery Cut Off voltage	600Vdc (+/-300 Vdc)							
Charger Max (A)	5.5	13	14	20	27	40.5	54	73
Battery Installation	External							
Battery Test Automatic	Standard every 72 Hours (Adjustable)							
Battery Protection	Polarity Protection/ Short Circuit Protection /Automatic Circuit Breaker / Fuses							

3.4 INVERTER SPECIFICATIONS

Model	EL 310	EL 320	EL 330	EL 340	EL 360	EL 380	EL 3100	EL 3120
Inverter Bridge	IGBT Technology							
Nominal Output Voltage	380 / 400 VAC 3 phase + N							
Output Frequency	50 Hz (60 Hz On Request)							
Output Frequency Tolerance - Free Running - Line Synchronized	± 0.2 % ± 2 %							
Overload Capability	120% Load: Continuous 125-150% Load: 1 min >150% Load: By pass							
Harmonic Distortion - Linear Load - Non Linear Load	< 2 % < 5 %							
Crest Factor	3/1							
Output Waveform	Sine Wave							
Short Circuit Protection	Electronic Short Circuit Protection							

3.5 BYPASS SPECIFICATIONS

Primary Components	Electronic SCR Switch
Nominal Voltage -V	380 / 400 VAC 3 phase + N
Nominal Frequency - Hz	50 Hz ± 5%
Retransfer : Static By-Pass to Inverter	Automatic and Manual
Overload Capability	150 – 200 % Continuously
Manual By-Pass	Without Interruption

3.6 OPTIONAL EXTRAS

Input/output voltage	110/208 VAC 3 Phase
Input transformer	Galvanic isolation transformer at the input & output
Adaptors	SNMP, MODBUS, Remote Monitoring Panel, RS485
Communication	RS232 & DRY Contacts
Software	T-Mon UPS Management (Standard for 3 Clients + 1 Server)

3.7 MECHANICAL SPECIFICATIONS

Model	EL 310	EL 320	EL 330	EL 340	EL 360	EL 380	EL 3100	EL 3120
Dimension (h x w x d)	1035 x 400 x 855				1450 x 515 x 855			
Weight (without battery) kgs	91	101	175	180	195	244	259	300
Protection Level	IP20							
Colour	Blue							

3.8 MAXIMUM OUTPUT MCB

Model	EL 310	EL 320	EL 330	EL 340	EL 360	EL 380	EL 3100	EL 3120
Maximum MCB size to be used in Final Distribution	B4	B6	B6	C10	C16	C25	C25	C32

3.8 MAXIMUM INRUSH CURRENT

Model	EL 310	EL 320	EL 330	EL 340	EL 360	EL 380	EL 3100	EL 3120
Maximum Output Inrush per Phase (Instantaneous)	39A	78A	117A	157A	274A	365A	457A	548A

3.9 HEAT DISSIPATION

At 100% Load, Battery fully charged, running inverter mode

Model	EL 310	EL 320	EL 330	EL 340	EL 360	EL 380	EL 3100	EL 3120
kW	0.54	1.08	1.62	2.16	3.24	4.32	5.4	6.48
kcal (x1000)	0.46	0.93	1.39	1.86	2.79	3.72	4.65	5.58
BTU (x1000)	1.84	3.69	5.53	7.37	11.06	14.74	18.43	22.11

At 100% Load, Battery fully discharged, running inverter mode

Model	EL 310	EL 320	EL 330	EL 340	EL 360	EL 380	EL 3100	EL 3120
kW	0.74	1.55	2.13	2.89	4.22	5.79	7.36	9.09
kcal (x1000)	0.64	1.34	1.83	2.48	3.63	4.98	6.33	7.82
BTU (x1000)	2.52	5.30	7.26	9.85	14.40	19.76	25.11	31.03

At 100% Load, Battery fully charged, running changeover mode

Model	EL 310	EL 320	EL 330	EL 340	EL 360	EL 380	EL 3100	EL 3120
kW	0.18	0.36	0.54	0.72	1.08	1.44	1.80	2.16
kcal (x1000)	0.15	0.31	0.46	0.62	0.93	1.24	1.55	1.86
BTU (x1000)	0.61	1.23	1.84	2.46	3.69	4.91	6.14	7.37

At 100% Load, Battery fully discharged, running changeover mode

Model	EL 310	EL 320	EL 330	EL 340	EL 360	EL 380	EL 3100	EL 3120
kW	0.38	0.83	1.05	1.45	2.06	2.91	3.76	4.77
kcal (x1000)	0.33	0.72	0.90	1.24	1.77	2.50	3.24	4.11
BTU (x1000)	1.30	2.84	3.58	4.93	7.03	9.93	12.83	16.29

At 120% Load, Battery fully discharged, running changeover mode

Model	EL 310	EL 320	EL 330	EL 340	EL 360	EL 380	EL 3100	EL 3120
kW	0.22	0.43	0.65	0.86	1.30	1.73	2.16	2.59
kcal (x1000)	0.19	0.37	0.56	0.74	1.12	1.49	1.86	2.23
BTU (x1000)	0.74	1.47	2.21	2.95	4.42	5.90	7.37	8.84